

## Never Struggle to Sharpen a Knife Again

- Push Button Start
- Improved Safety
- Easy to store

**MSRP: \$49.99**

### TARGET MARKET

74.46 million US Households likely to sharpen knives at home. Project to capture 5%.

**Cumulative Sales after 3 years: \$4.75 million**



Outside View

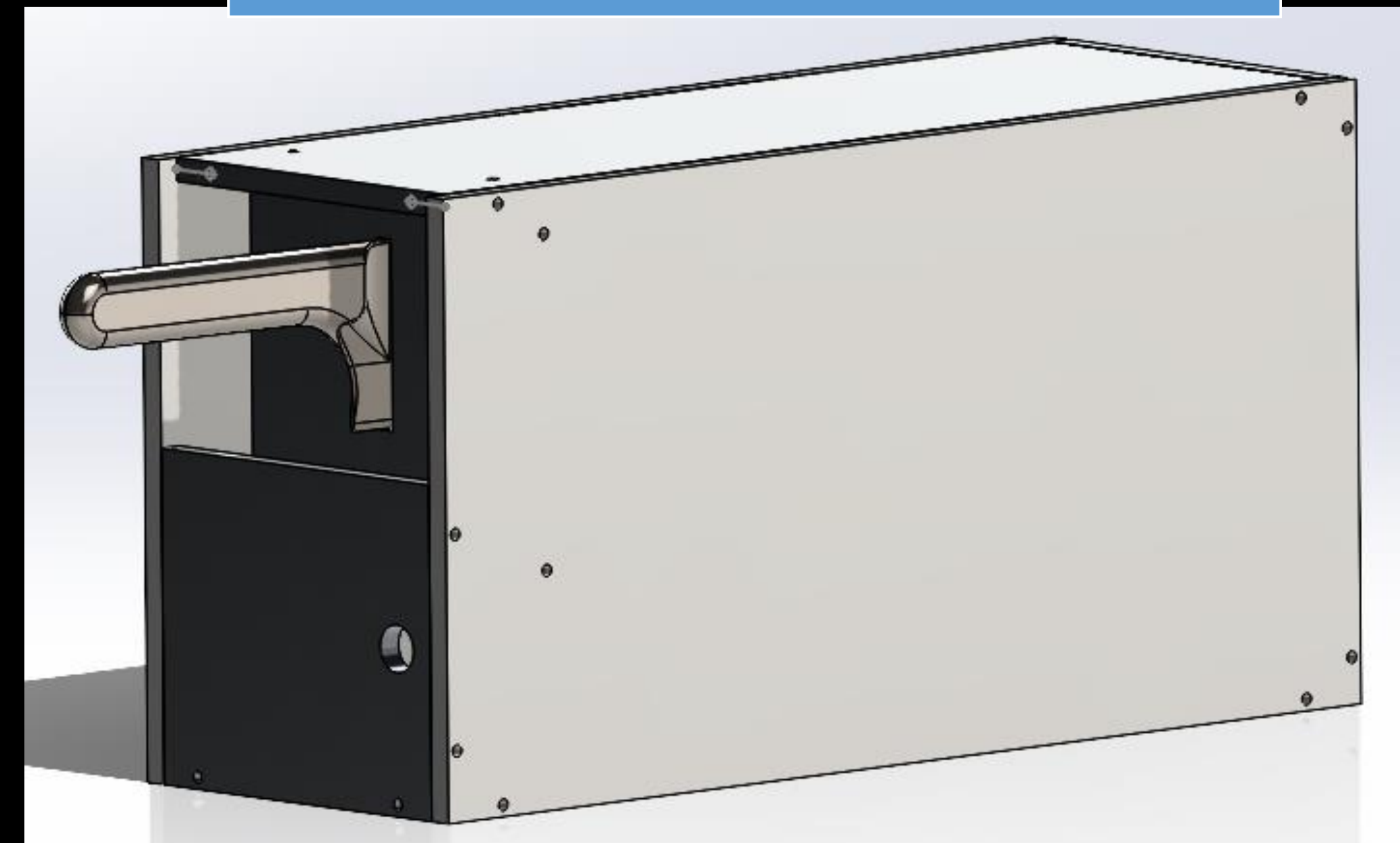

Inside View

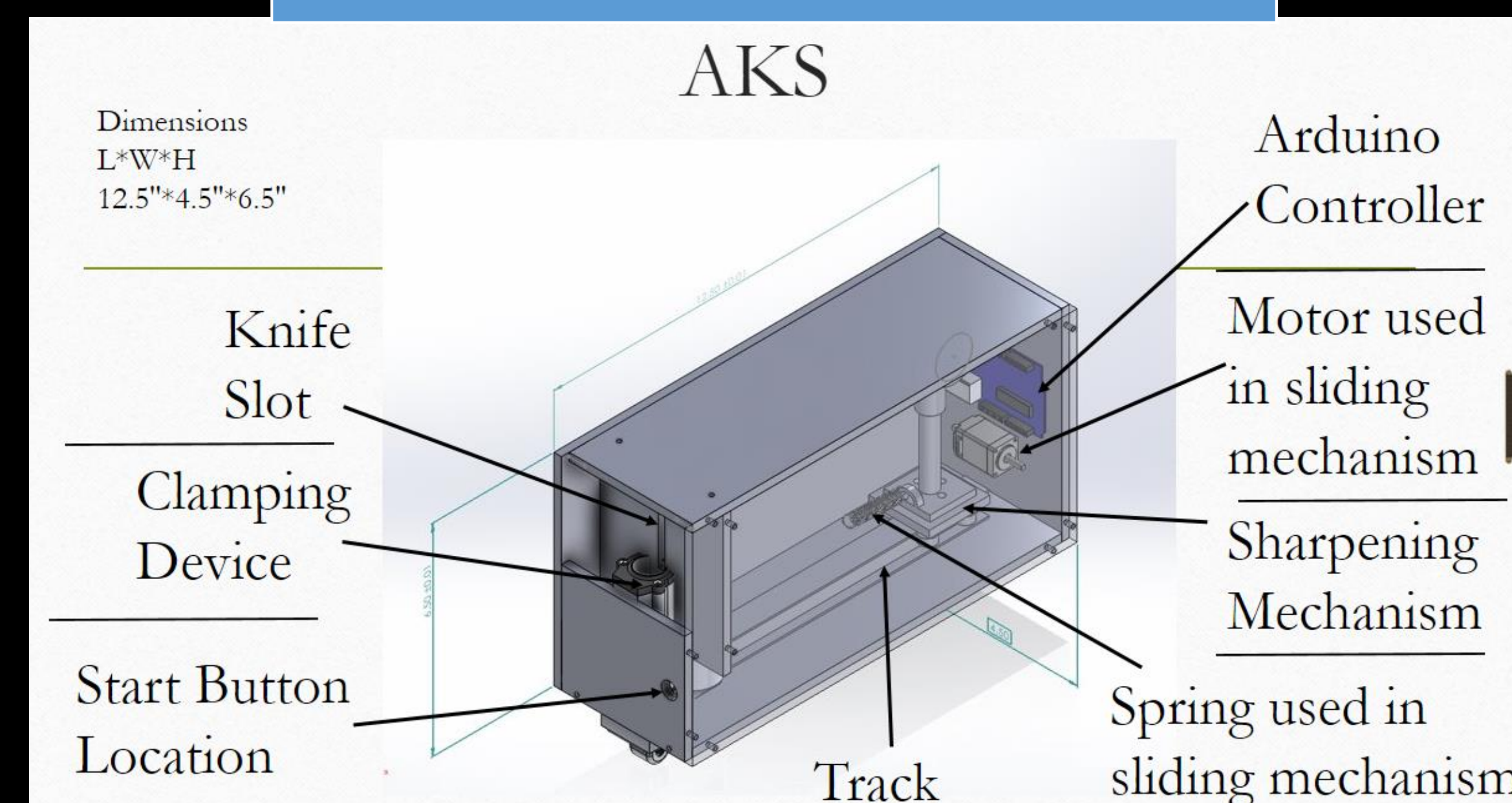

### Value Proposition

The Auto Knife Sharpener offers users the ability to sharpen multiple knives at a time with the push of a button. This allows for a quick, safe, and efficient method to provide the customer with a pristine blade.

Feature	Function	Benefits
Automatically Sharpens Knives	Sharpens Knives	Don't have to manually sharpen your knives
Closed Case Sharpener	Fully Enclosed Sharpening	Safely sharpens knives
Self-timing Sharpener	Internal Timer	Doesn't damage the knife
Knife Clamp	Holds knife in place while sharpening	Ensures the knife is in line with the sharpener

**Team Members: Spencer Annable, Dan Buell, Josh Gill, Katelyn Griffin, Courtney Thompson**